

G.C.C

DENOMINATION

Sparkling E 75cl

MODEL Nr

214

Mold. N° 03028

TECHNICAL DATE

Capacity: 750 ml
Capacity Brimf: 775±10ml
Weight: (grs.) 600
Finish : 0
Colour: green

Thickness of the glass bottle walls:
not less than 1.5mm.

Thickness of the glass bottle bottom:
not less than 3mm.

USE LIMITS

Carbonated level :
Termoshock: not less than: 40°C
Pressure(bar): not less than 14
Axial loading max.(kg.)
Vertical durability max.(kg)

TOLERANCES (mm)

Verticality: ± 3.3
Height: ± 1.8
Diameter: ± 1.6

SURFACE TREATMENT

Hot end coating : yes
Cold end coating : yes

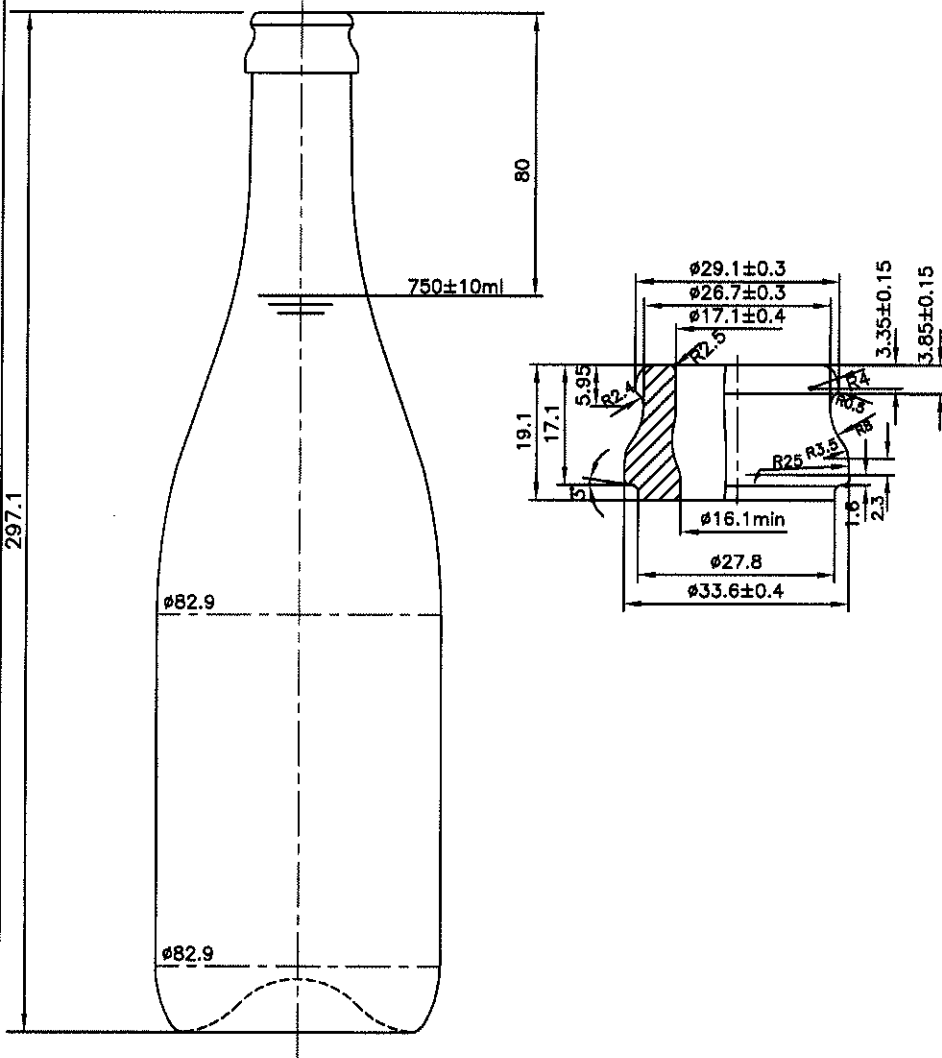

LAYOUT OF BOTTLES IN A PALLET

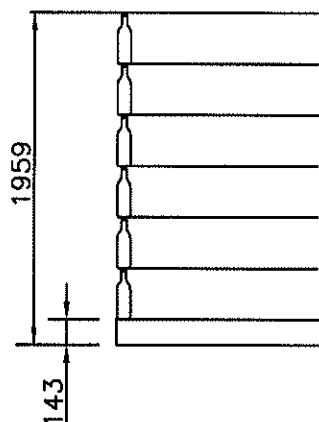
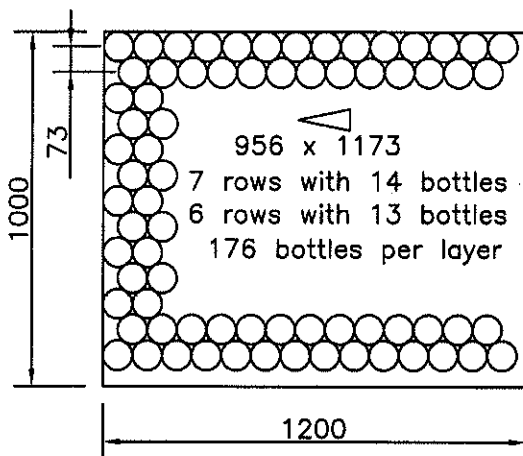

Nr of layers in a pallet: 6
Nr of bottles in a pallet : 1056
Pallet weight (Kg): 634

Pallet : 1200x1000
Lower tray : 1050x1200
Middle tray : 1050x1200
Cover: Cardboard
Wrappage : shrinkwrap film